



TTZ

Limited-Clearance Tool

FEATURES

- Multi-position hose couplers prevents hose interference on all jobs
- Simply connect hex links for quick and easy hex size changes
- Efficient design allows for simple and inexpensive repairs of internal parts
- Slim design allows tool to fit where a square drive tool can't
- Highest quality internal metals for durability and longevity
- Manufactured and assembled in the U.S.A. with supreme quality control

SPECIFICATIONS

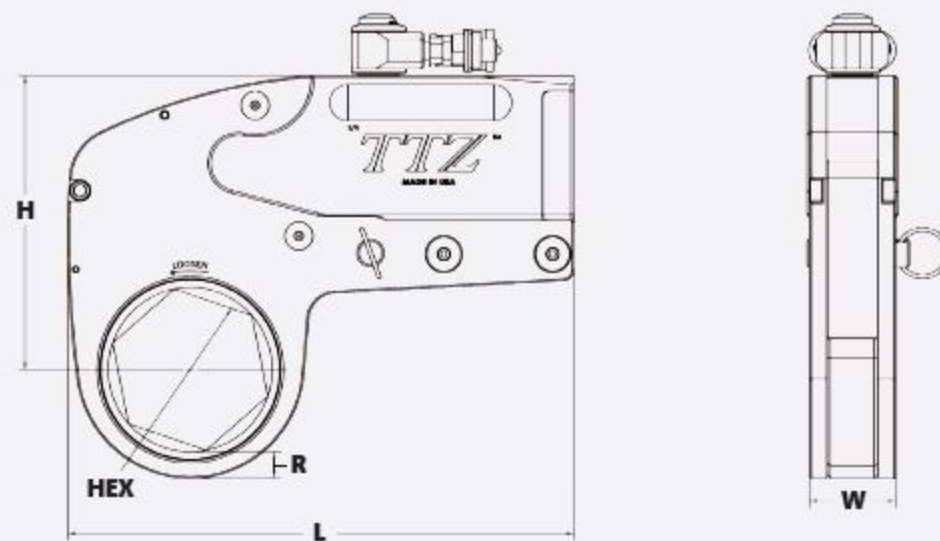

LEGEND: H = HEIGHT L = LENGTH R = RADIUS W = WIDTH

Model		H	W	L	R	Hex Range	Weight	Torque	
								MIN.	MAX.
TTZ-2	in.	3.73	1.25	6.97	0.38	.75 – 2.9375	3.30 lbs.	269 ft.-lbs.	1,875 ft.-lbs.
	mm	95	32	177	10	1	1.50 kg	364.72 Nm	2,542.16 Nm
TTZ-4	in.	5.51	1.67	9.20	0.51	1.4375 – 3.5	7.20 lbs.	655 ft.-lbs.	4,538 ft.-lbs.
	mm	140	42	234	13	1	3.27 kg	888.06 Nm	6,152.70 Nm
TTZ-8	in.	6.53	2.10	11.62	0.72	2 – 3.875	11.90 lbs.	1,202 ft.-lbs.	8,308 ft.-lbs.
	mm	166	53	295	18	2	5.40 kg	1,629.69 Nm	11,264.14 Nm
TTZ-14	in.	8.04	2.50	13.88	0.73	2.75 – 4.625	19.30 lbs.	2,062 ft.-lbs.	14,576 ft.-lbs.
	mm	204	64	353	19	3	8.75 kg	2795.70 Nm	19,762.40 Nm
TTZ-20	in.	8.87	3.00	14.81	0.92	2.75 – 6	25.00 lbs.	3,080 ft.-lbs.	21,891 ft.-lbs.
	mm	225	76	376	23	3	11.34 kg	4175.92 Nm	29,680.21 Nm
TTZ-30	in.	10.95	3.75	18.52	1.00	3.125 – 7.625	47.70 lbs.	5,394 ft.-lbs.	36,777 ft.-lbs.
	mm	278	95	470	25	3	21.64 kg	7,313.28 Nm	49,862.92 Nm

NOTE:

All tools and pumps are subject to a 13-months free repair/replacement guaranty in the event of failure. Data subject to change without notice.